



Air Starters

3BMG/5BMG Series



For engine displacement of: Diesel—up to 500 CID (8 liters)
Carburated—up to 1000 CID (16 liters)

Features/Benefits

- All models sealed for use in air or gas applications
- Inertia drive for fast, reliable starts
- Compact, inline design
- 9.5 hp motor on 5BMG;
8.4 hp motor on 3BMG
- Back ports for injection lubricating

Versatile

- 4 inlet, 4 exhaust, and 12 drive housing orientations
- Fits a wide range of small and medium size engines
- 90-150 psi (6.2-10.3 bars) operation



Industry applications ideal for the 3BM/5BM Series starters: oil and gas production, shipping, trucking.



Air Starters

3BMG Series DIMENSIONS

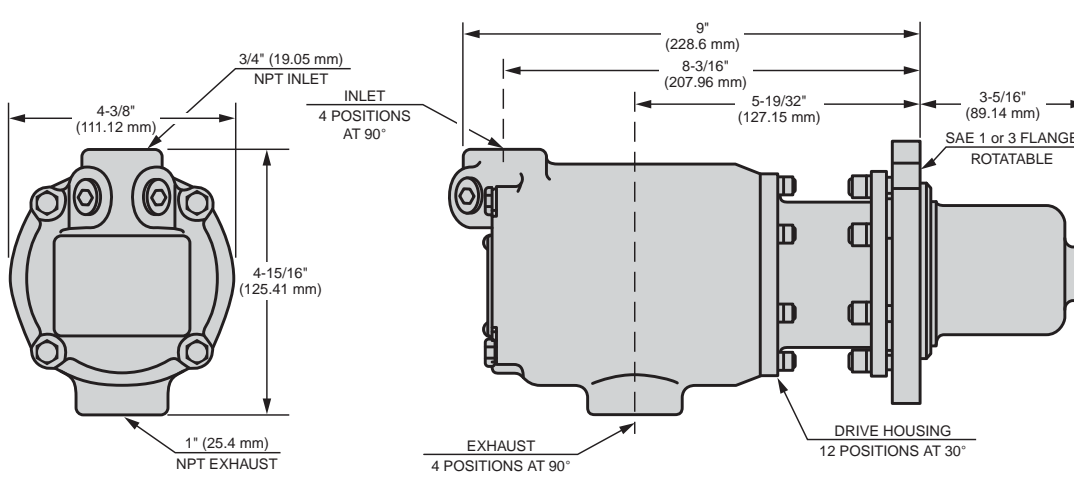

Weight lbs (kg)	
3BMG	18 (8.2)



5BMG Series DIMENSIONS

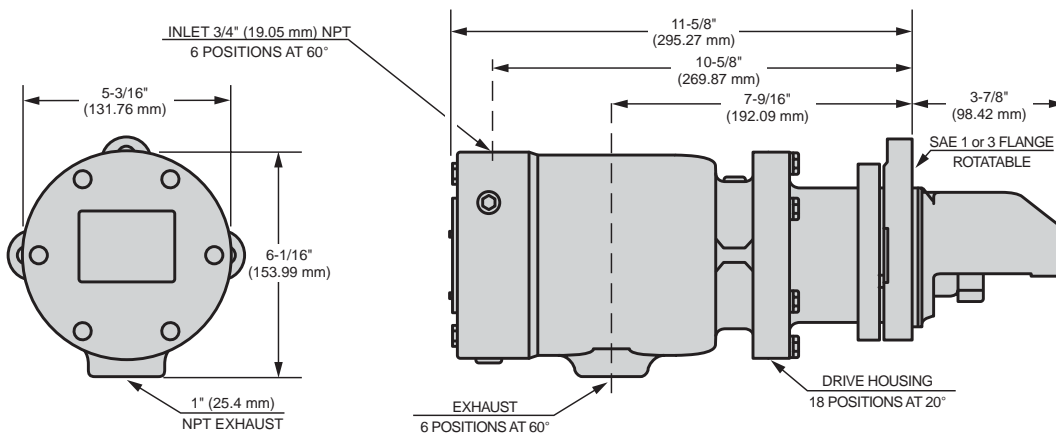

Weight lbs (kg)	
5BMG	35 (15.9)



3BMG/5BMG Series

3BMG Series Performance Information

Pressure PSI (bar)	Breakaway Torque ft-lb (Nm)	Speed @ Max HP RPM	Max Power HP (kw)	Flow @ Max HP SCFM (L/s)
90 (6.2)	23 (31)	2100	4.8 (4)	150 (71)
120 (8.3)	28 (38)	2500	6.7 (5)	220 (104)
150 (10.3)	36 (49)	3200	8.4 (6)	325 (153)

5BMG Series Performance Information

Pressure PSI (bar)	Breakaway Torque ft-lb (Nm)	Speed @ Max HP RPM	Max Power HP (kw)	Flow @ Max HP SCFM (L/s)
90 (6.2)	28 (38)	2100	5.0 (4)	165 (78)
120 (8.3)	35 (47)	2500	7.5 (6)	220 (104)
150 (10.3)	42 (57)	2700	9.5 (7)	310 (146)

3BMG Series Number of Starts per Tank

(Assuming 1-Second Crank Time @ 90 PSI)

300	35	52	70	87	105	122	140	157	20	Max Tank Pressure (psi)	Max Tank Pressure (bar)	
270	31	46	61	76	92	107	122	138	18			
240	26	39	52	65	79	92	105	118	16			
210	22	33	44	55	65	76	87	98	14			
180	17	26	35	44	52	61	70	79	12			
150	13	20	26	33	39	46	52	59	10			
120	9	13	17	22	26	31	35	39	8			
90	4	7	9	11	13	15	17	20	6			
	40	60	80	100	120	140	160	180				Gallons Liters
	151	227	302	378	454	529	605	680				
	Tank Size											

5BMG Series Number of Starts Per Tank

(Assuming 1-Second Crank Time @ 90 PSI)

300	32	48	63	79	95	111	127	143	20	Max Tank Pressure (psi)	Max Tank Pressure (bar)	
270	28	42	56	69	83	97	111	125	18			
240	24	36	48	60	71	83	95	107	16			
210	20	30	40	50	60	69	79	89	14			
180	16	24	32	40	48	56	63	71	12			
150	12	18	24	30	36	42	48	54	10			
120	8	12	16	20	24	28	32	36	8			
90	4	6	8	10	12	14	16	18	6			
	40	60	80	100	120	140	160	180				Gallons Liters
	151	227	302	378	454	529	605	680				
	Tank Size											