

TDI

TURBOTWIN™

Model T100-B

TURBOTWIN™ Model T100-B **ENGINE AIR STARTERS**

- The TDI *TURBOTWIN* T100-B starter is suitable for starting either gas or diesel models up to 250 liters (15000 CID). see installation and selection guidelines. This includes Caterpillar G3500 series, Cooper Ajax DPC 600 & 800, and Waukesha L7040G engine.
- The turbine motor used in the model T100-B is the same rugged design used in the complete line of *TURBOTWIN* starters. Properly installed, the *TURBOTWIN* motor is highly resistant to damage caused by wet or hard contaminated drive air/gas.
- Installation requires only a starter relay valve (recommend TDI *TURBOVALVE*), and operation within each starter model recommended maximum pressure. The T100-B features modular construction and individual parts are easily serviced. This provides T100-B users with simple and low cost starter repair and overhaul in the future. The T100-B air starter requires no control lines or electrical wiring for its operation, therefore the unit is ideal for remote start or "black" start conditions or applications.
- The T100-B's efficient twin-turbine motor now delivers more torque using less air/gas than previous starter designs. The T100-B is offered in both standard pressure (12 nozzle) and low pressure (21 nozzle) versions.
- The gear train and bearings are factory grease-packed for the life of the starter, therefore it requires no maintenance. There are no rubbing parts, so there is no external lubrication required. Lubricator problems, installation expense, system maintenance, and the messy and hazardous oil film around the starter exhaust can be eliminated.
- *TURBOTWIN* T100-B starters are constructed from durable, corrosion resistant, and high quality materials. Major components are made from high strength aluminum or steel alloy. As with all *TURBOTWIN* T100 Series starters, there are no plastic parts inside.
- The T100-B can be used over a wide range of drive pressures from 30 psig (2 BAR) to 150 psig (10 BAR). It is suitable for operation on either compressed air or natural gas. The lightweight, 48 Lb. (22 KG) unit is capable of delivering over 80 HP (60 kW) of cranking power at only 150 psig (10 BAR).

**APPLICATION
VERSATILITY**

**CONTAMINATED
SUPPLY AIR/GAS**

SIMPLICITY

**LOW AIR
CONSUMPTION**

**NO MAINTENANCE
DESIGN and
ENVIRONMENTALLY
SAFE**

**HEAVY DUTY
CONSTRUCTION**

**BROAD RANGE of
OPERATION**

from **TECH DEVELOPMENT INC.**

6800 Poe Avenue •Dayton, OH 45413
Tel: 937-898-9600 •Fax: 937-898-8431

- The high horsepower of the turbine air motor combined with a planetary gear speed reducer results in a very efficient and reliable unit. A pair of axial flow turbines coupled to a planetary gear reduction set powers the *TURBOTWIN* T100-B. The T100-B models incorporate an inertia drive coupled to the starter gearbox drive train to provide a means of engaging and disengaging the pinion from the engine ring gear.
- Tech Development Inc. introduced the first turbine technology for starting industrial engines in 1979. The *TURBOTWIN* T100-B starters feature an innovative and more reliable turbine motor than anything on the market today. The *TURBOTWIN* T100-B is the result of TDI's continuing turbine starter design innovations.

DESCRIPTION OF OPERATION

DEVELOPMENT HISTORY

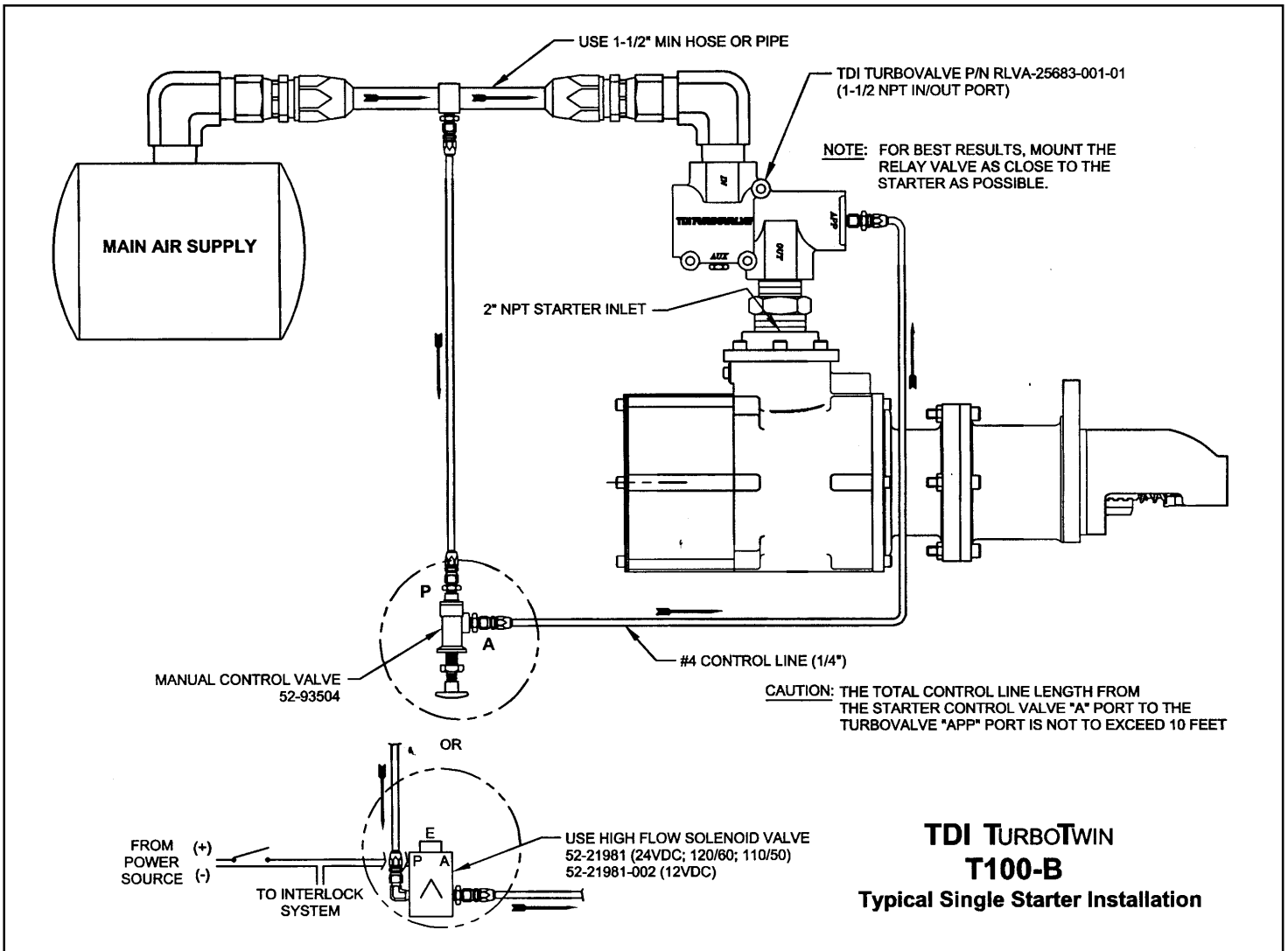

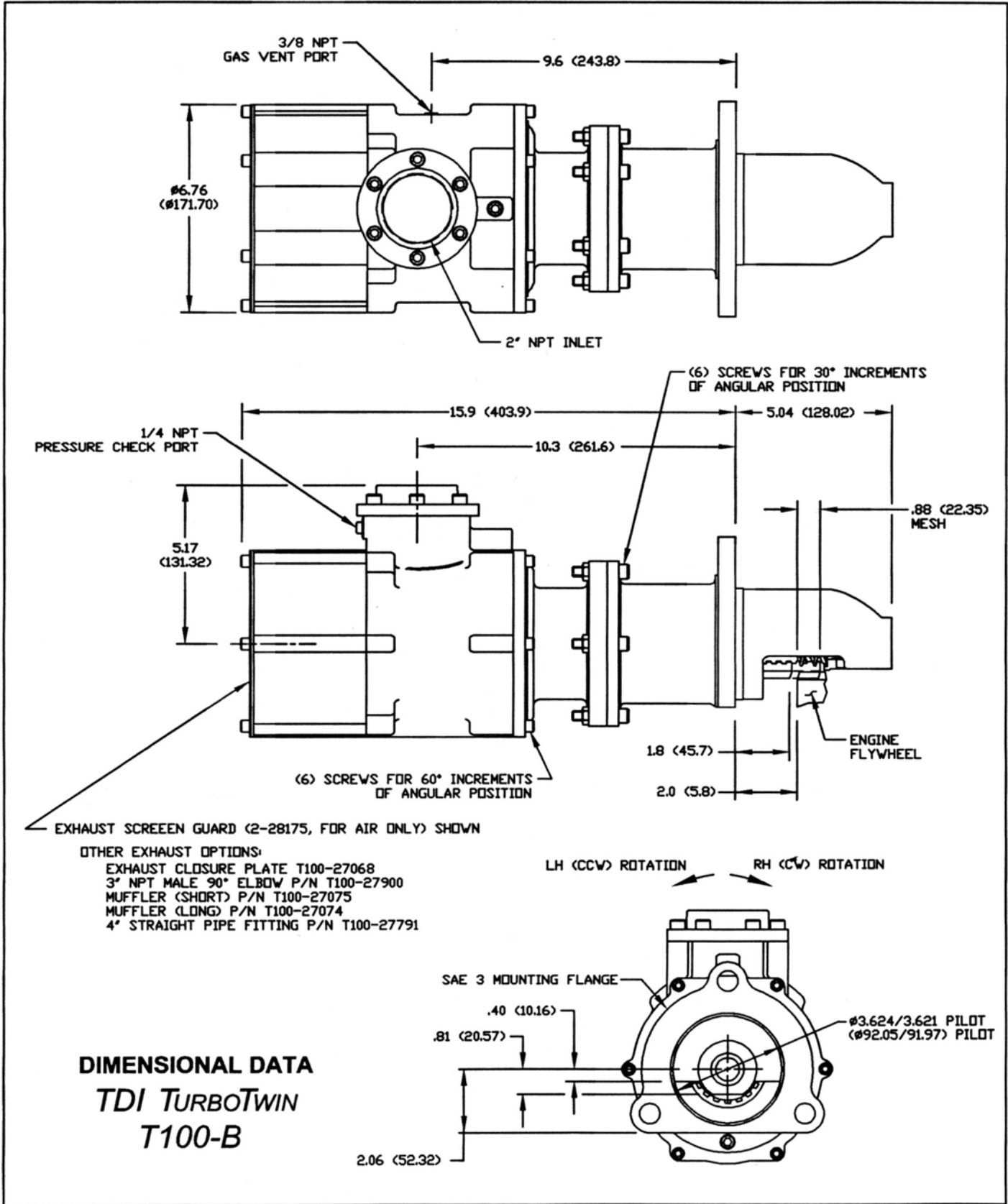

DIMENSIONAL DATA
TDI TURBOTWIN
T100-B

from **TECH DEVELOPMENT INC.**
 6800 Poe Avenue • Dayton, OH 45413
 Tel: 937-898-9600 • Fax: 937-898-8431

TDI TURBO TWIN T100-B PERFORMANCE CURVES

Model: T112-B
12 Nozzles
70° F Compressed Air
7.5:1 Gear Ratio

INLET Pressure	FLOW (Scfm)	FLOW (Nm ³ /h)
60 PSIG	610	1037
90 PSIG	860	1462
120 PSIG	1090	1853
150 PSIG	1360	2312

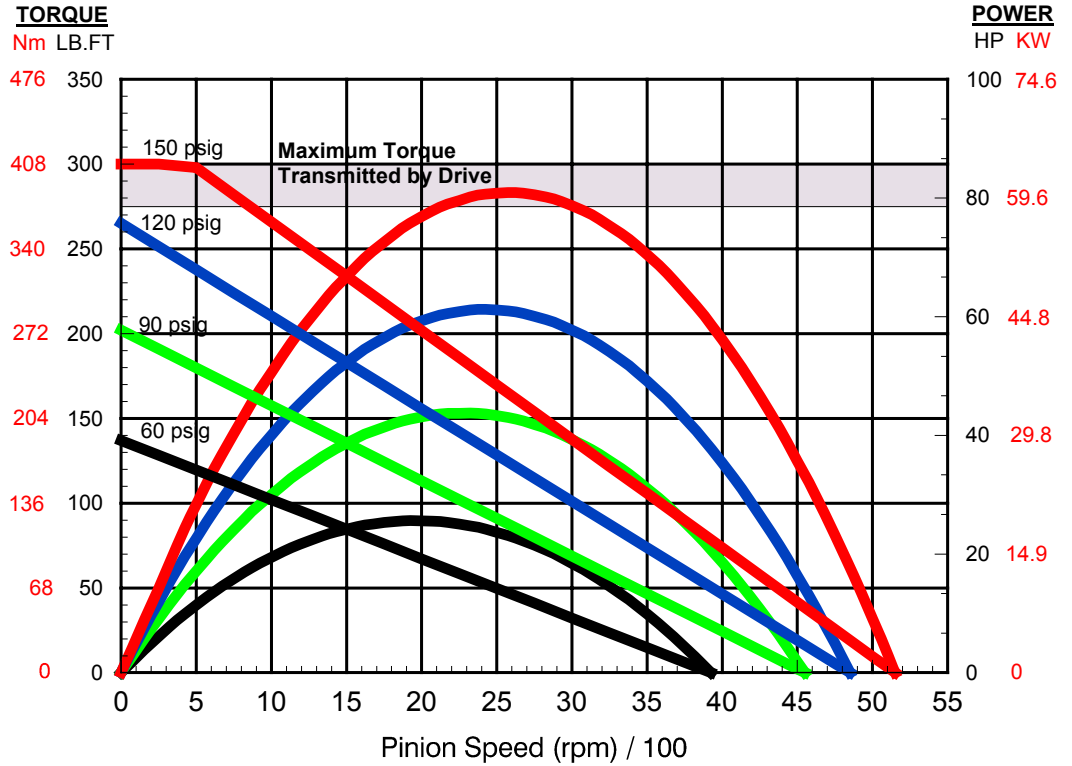

Model: T121-B
21 Nozzles
70° F Compressed Air
7.5:1 Gear Ratio

INLET Pressure	FLOW (Scfm)	FLOW (Nm ³ /h)
30 PSIG	620	1054
60 PSIG	1070	2140
90 PSIG	1560	2652

